



basic education

Department:
Basic Education
REPUBLIC OF SOUTH AFRICA

NATIONAL SENIOR CERTIFICATE

GRADE 12

MECHANICAL TECHNOLOGY

NOVEMBER 2013

MARKS: 200

TIME: 3 hours

This question paper consists of 14 pages and a 5-page formula sheet.

INSTRUCTIONS AND INFORMATION

1. Write your centre number and examination number in the spaces provided on the ANSWER BOOK.
2. Read ALL the questions carefully.
3. Answer ALL the questions.
4. Number the answers correctly according to the numbering system used in this question paper.
5. Start EACH question on a NEW page.
6. Show ALL calculations and units. Round off final answers to TWO decimal places.
7. Candidates may use non-programmable scientific calculators and drawing instruments.
8. The value of gravitational force should be taken as 10 m/s^2 .
9. All dimensions are in millimetres, unless stated otherwise in the question.
10. Write neatly and legibly.
11. Use the criteria below to assist you to manage your time.

QUESTION	ASSESSMENT STANDARDS	CONTENT	MARKS	TIME
1	1–9	Multiple-choice Questions	20	18 minutes
2	2	Tools and Equipment	20	18 minutes
3	3	Materials	20	18 minutes
4	1, 4 and 5	Safety, Terminology and Joining Methods	50	45 minutes
5	7 and 9	Maintenance and Turbines	40	36 minutes
6	6 and 8	Forces and Systems and Control	50	45 minutes
TOTAL			200	180 minutes

QUESTION 1: MULTIPLE-CHOICE QUESTIONS

Various options are provided as possible answers to the following questions. Choose the answer and write only the letter (A–D) next to the question number (1.1–1.20) in the ANSWER BOOK, for example 1.21 D.

- 1.1 Avoid using compressed air to clean chips from the milling machine because ...
- A it does the job too slowly.
 - B flying chips may cause eye injuries.
 - C it gives a poor finish to the job.
 - D it is too expensive. (1)
- 1.2 Before operating a lathe machine, you should ...
- A remove all safety guards.
 - B oil the area surrounding the machine.
 - C wear rings and jewellery.
 - D make sure you know the location of the ON and OFF switch. (1)
- 1.3 Which hardness tester uses a steel-ball indenter to measure the penetration into a metal under a specified load?
- A Webster hardness tester
 - B Rockwell hardness tester
 - C Brinell hardness tester
 - D Vickers hardness tester (1)
- 1.4 A Grade 12 learner uses a multimeter during simulation of a circuit. What can be measured with a multimeter?
- A Diode and continuity measurement
 - B Transistor velocity
 - C Length of the conductor
 - D Thickness of the conductor (1)
- 1.5 Carbon steels are identified according to their carbon content percentage. Low-carbon steel contains less than ...% carbon.
- A 0,45
 - B 0,3
 - C 0,7
 - D 1,5 (1)

1.6 ... is added to steel when toughness, hardness and wear resistance are desired.

- A Copper
- B Aluminium
- C Lead
- D Tungsten

(1)

1.7 The lathe operates on the principle of ...

- A the cutter revolving against the work piece.
- B the cutting tool, that can be controlled, can be moved vertically across the work piece.
- C the work piece rotating against the cutting tool, which can be controlled.
- D both cutter and work piece rotating.

(1)

1.8 The largest piece of material that can be turned between centres is equal to the ...

- A length of the bed minus the space taken up by the headstock.
- B length of the bed minus the space taken up by the tailstock.
- C length of the bed minus the space taken up by the headstock and the tailstock.
- D total length of the bed.

(1)

1.9 Identify the milling process in FIGURE 1.1 below:

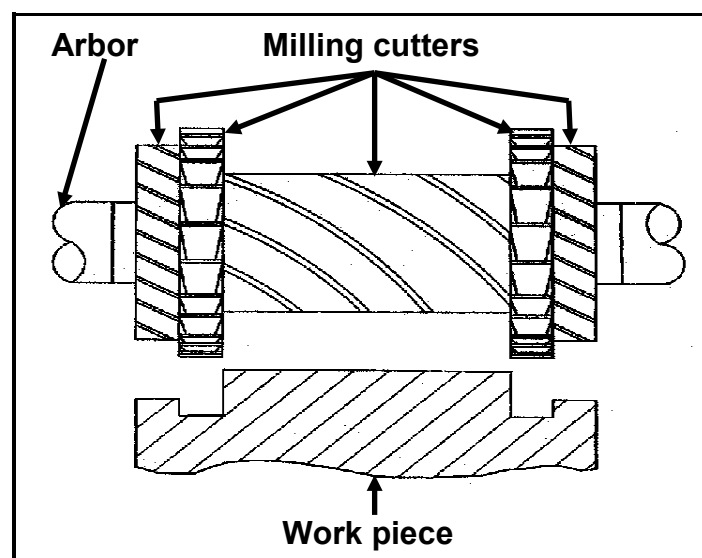

FIGURE 1.1

- A Gang milling
- B Slab milling
- C Straddle milling
- D Up-cut milling

(1)

- 1.10 Ultrasonic inspection techniques use ... waves to detect flaws in welded joints.
- A air
 - B light
 - C electronic
 - D sound
- (1)
- 1.11 Which TWO bottled gases are used for the MIG welding process?
- A Argon and carbon dioxide (CO₂)
 - B Argon and carbon monoxide
 - C Acetylene and oxygen
 - D Oxygen and argon
- (1)
- 1.12 Which ONE of the following describes Hooke's law?
- A Instantaneous force divided by the original cross-sectional area of the test material
 - B Stress value required to produce unit strain in a tensile specimen of the particular material
 - C Strain is directly proportional to the stress causing it, provided the limit of elasticity is not exceeded
 - D A measurement of the deformation produced by the application of the external forces
- (1)
- 1.13 What is strain?
- A Determined by dividing the load by the smallest actual cross-sectional area of the test specimen
 - B The ratio between the original length and the change in length when an external force is applied
 - C The amount of stress that a material can absorb without exceeding its breaking stress
 - D A measurement of the deformation produced by the application of an external force
- (1)
- 1.14 Where is EP 90 oil used?
- A Engine
 - B Power steering
 - C Brakes
 - D Gearbox
- (1)

1.15 Mineral oils ...

- A are used where the load, speed and temperature is low.
- B provide increased heating capacity in some applications.
- C range from milky to transparent in appearance.
- D are composed of oil droplets. (1)

1.16 A windscreen wiper motor generates rotary motion which is converted into the motion operating the wiper blades. In which motion are the wiper blades operating?

- A Rotary
- B Reciprocating (in straight line)
- C Oscillating (pendulum motion)
- D Linear (1)

1.17 Identify the type of screw thread in FIGURE 1.2 below:

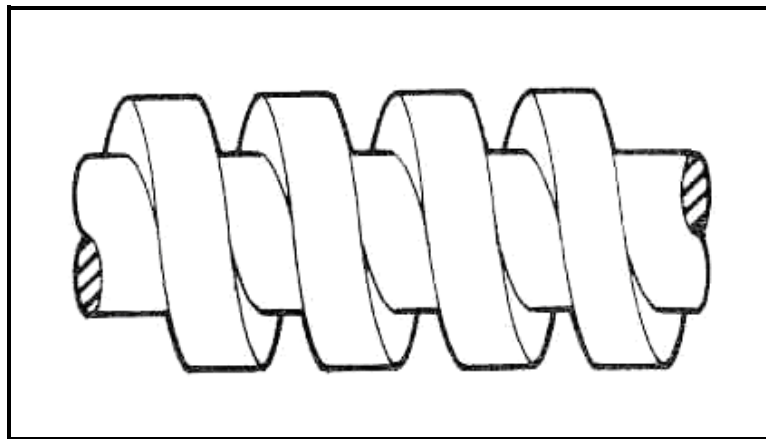

FIGURE 1.2

- A V-screw thread
- B Square screw thread
- C Acme screw thread
- D ISO Metric screw thread (1)

- 1.18 What is the stroke length (**X**) moved by the follower for the pear-shaped cam shown in FIGURE 1.3 below, given that $d_1 = 6$ mm and $d_2 = 12$ mm?

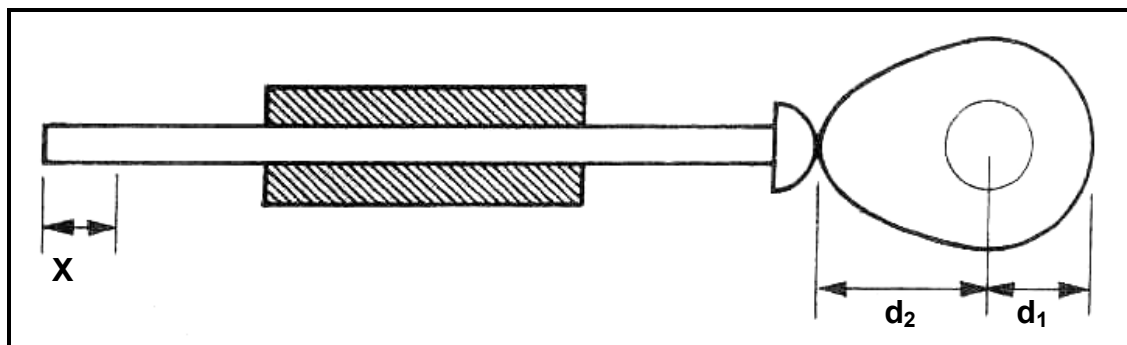

FIGURE 1.3

- A 18 mm
 B 24 mm
 C 2 mm
 D 6 mm (1)
- 1.19 A steam turbine is used to ...
 A increase the fuel consumption in relation to engine output.
 B increase the volumetric efficiency of an engine.
 C drive a generator to generate electricity.
 D decrease the atmospheric pressure of an engine. (1)
- 1.20 What will the volumetric efficiency be if a 100 mm^3 blower displaces 83 mm^3 per revolution?
 A 83%
 B 17%
 C 103%
 D 100% (1)
[20]

QUESTION 2: TOOLS AND EQUIPMENT

- 2.1 In terms of lathes and milling machines, what does the abbreviation *CNC* stand for? (2)
- 2.2 State THREE advantages of a CNC machine. (3)
- 2.3 State ONE disadvantage of a CNC machine. (1)
- 2.4 Identify and specify the type of equipment used to test the resistance to bending, scratching, abrasion and/or cutting. (2)
- 2.5 A taxi driver notices that his vehicle loses power. The mechanic will have to conduct a compression test according to certain procedures. Give the reason for carrying out each of the following procedures:
- 2.5.1 Removing the high-tension leads (1)
- 2.5.2 Unplugging the fuel injectors (1)
- 2.5.3 Fully opening the throttle valve (1)
- 2.5.4 Recording the readings (1)

2.6 FIGURE 2.1 below shows a typical tester used in a mechanical workshop. Answer the questions that follow.

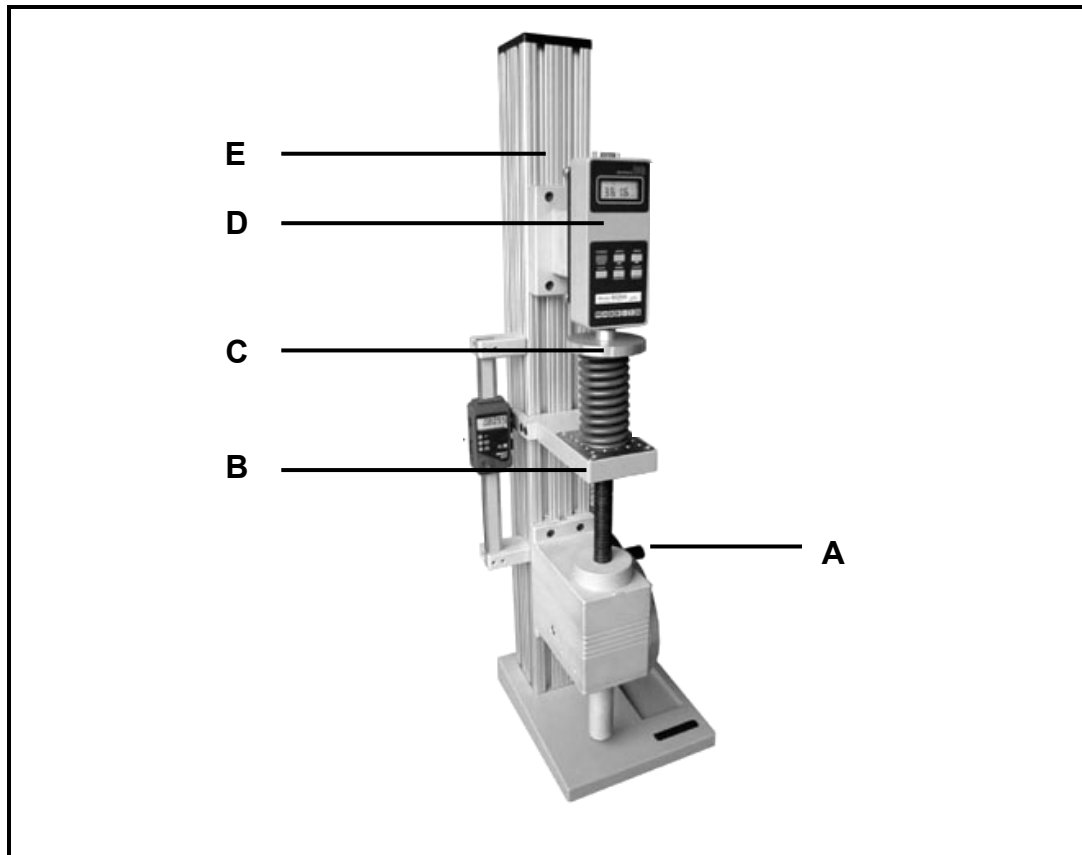

FIGURE 2.1

- 2.6.1 Identify the tester shown in FIGURE 2.1. (1)
- 2.6.2 Label the parts of the tester marked **A–E**. (5)
- 2.6.3 State the purpose of the tester shown in FIGURE 2.1. (2)
- [20]**

QUESTION 3: MATERIALS

3.1 The wheel rims on some vehicles are manufactured from mild steel. Others are cast in aluminium alloys. Answer the questions that follow.

3.1.1 Give THREE reasons for choosing to manufacture vehicle wheel rims out of aluminium alloy. (3)

3.1.2 Give TWO reasons why the wheel rims of heavy-duty vehicles (trucks) are manufactured from steel. (2)

3.2 FIGURE 3.1 below shows tin snips. Answer the questions set on the tin snips.



FIGURE 3.1

3.2.1 What material is used to manufacture the blades? Give a reason for your answer. (2)

3.2.2 Why is it necessary to smear oil on the blades? (1)

3.3 Explain why alloys are produced. Give FOUR reasons. (4)

3.4 The materials traditionally used in the manufacturing industry are being replaced at an alarming rate by a new generation of materials, like thermoplastics and thermosetting plastics. Answer the questions that follow.

3.4.1 Explain the difference between *thermoplastics* and *thermosetting plastics*. (4)

3.4.2 Give ONE example of each of the plastics mentioned in QUESTION 3.4.1. (2)

3.5 Why is carbon fibre used in the automotive manufacturing industry? Give TWO reasons. (2)

[20]

QUESTION 4: SAFETY, TERMINOLOGY AND JOINING METHODS

- 4.1 Sipho is using a bearing puller to remove bearings from a shaft. List FIVE safety rules for the safe use of a bearing puller. (5)
- 4.2 Specify FIVE general safety rules to be considered when using equipment like the lathe and drill press. (5)
- 4.3 Calculate the feed, in millimetres per minute, of an 80 mm diameter milling cutter with 24 teeth operating at a cutting speed of 35 metres per minute and cutting at a feed of 0,02 mm per tooth. (6)
- 4.4 A spur gear with 119 teeth must be machined onto a work piece. Hint: Use ($N = 120$ and $n = 119$ divisions) OR ($A = 120$ and $n = 119$ divisions) for the calculations. The dividing head ratio is 40 : 1.
- 4.4.1 Calculate the indexing needed for the operation. (6)
- 4.4.2 Calculate the change gears that must be installed on the dividing head. (6)
- 4.4.3 State the direction of rotation of the index plate in relation to the rotation of the index crank handle. (2)
- 4.5 Name THREE types of milling machines. (3)
- 4.6 Explain the functions of the following milling machine components:
- 4.6.1 Dividing head (2)
- 4.6.2 Index plate (2)
- 4.6.3 Spindle on the dividing head (2)
- 4.7 John works for Shai-Welco as a learner welder. Assist John by answering the questions that follow.
- 4.7.1 Name TWO causes of slag inclusion in a welded joint. (2)
- 4.7.2 Which TWO steps can be followed to prevent undercutting in a welded joint? (2)
- 4.7.3 Describe ONE step that can be followed to prevent incomplete penetration in a welded joint. (1)
- 4.7.4 What is the difference between a *destructive test* and a *non-destructive test* on materials? (2)
- 4.7.5 Name FOUR basic components of MIG/MAG welding machines. (4)

[50]

QUESTION 5: MAINTENANCE AND TURBINES

- 5.1 Define the following terms related to motor oils:
 - 5.1.1 Pour point (2)
 - 5.1.2 Viscosity (2)
- 5.2 Give FIVE functions of a good motor oil. (5)
- 5.3 Give THREE reasons for using cutting fluid when working on the centre lathe. (3)
- 5.4 Explain the functions of automatic transmission fluid. (3)
- 5.5 Name the type of motor oil and grading that is used in the following systems under South African conditions:
 - 5.5.1 Internal combustion engine (2)
 - 5.5.2 Manual transmission (2)
 - 5.5.3 Automatic transmission (2)
- 5.6 What is the gas turbine also known as? (1)
- 5.7 FIGURE 5.1 below shows the internal components of a turbocharger. Answer the questions that follow.

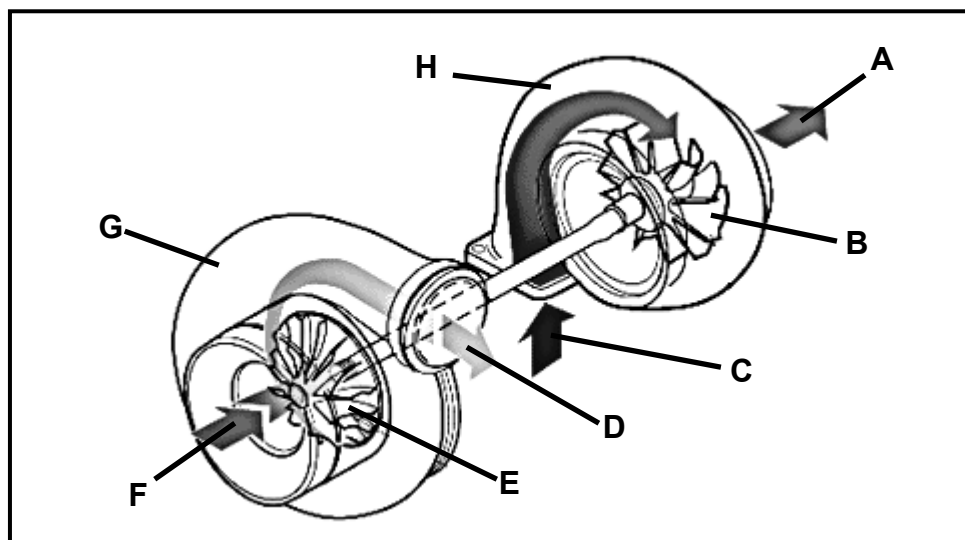

FIGURE 5.1

- 5.7.1 Label the components of the turbocharger marked **A–H** in FIGURE 5.1 above. (8)
- 5.7.2 Explain the operation of a turbocharger. (6)

5.8 Explain the following terms regarding the turbocharger:

5.8.1 Lag (2)

5.8.2 Boost (2)
[40]

QUESTION 6: FORCES AND SYSTEMS AND CONTROL

6.1 A hydraulic system is used to lift mechanical machines. The specifications of the system used are represented diagrammatically in FIGURE 6.1 below. The system is equipped with the necessary one-way control valves to prevent the fluid from flowing back after each stroke.

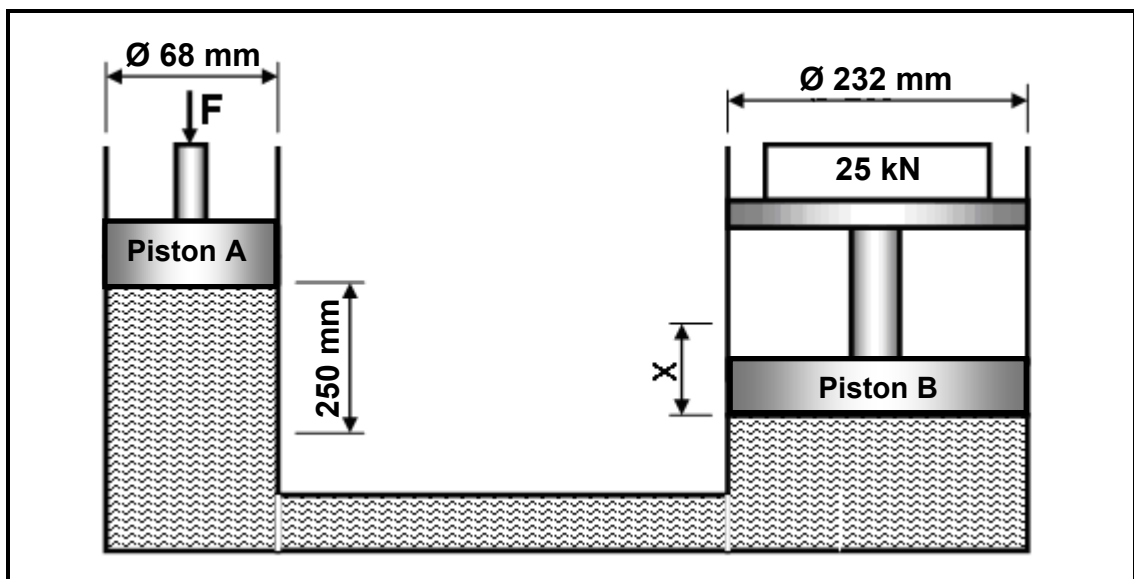

FIGURE 6.1

Determine, by means of calculations, the following: (Show ALL units.)

6.1.1 The fluid pressure in the hydraulic system when in equilibrium (6)

6.1.2 The force (**F**) that must be exerted onto piston **A** to lift the load of 25 kN on piston **B** (6)

6.1.3 The distance **X**, in millimetres, that piston **B** will move if piston **A** completes 10 strokes (6)

- 6.2 A load of 45 kN causes compressive stress of 18 MPa in a round brass bar. The original length of the bar is 185 mm and Young's modulus for brass is 90 GPa.

Determine, by means of calculations, the following:

- 6.2.1 The diameter, in millimetres, of the resistance surface of the round brass bar (8)
- 6.2.2 The strain caused by the load (4)
- 6.2.3 The change in length, in millimetres, caused by the load (3)
- 6.3 The V-belt drive system of a compressor is shown in FIGURE 6.2 below. The driver pulley of the belt drive system rotates at 2 700 r/min. The driver pulley has a diameter of 210 mm. The compressor shaft must rotate at 1 000 r/min.

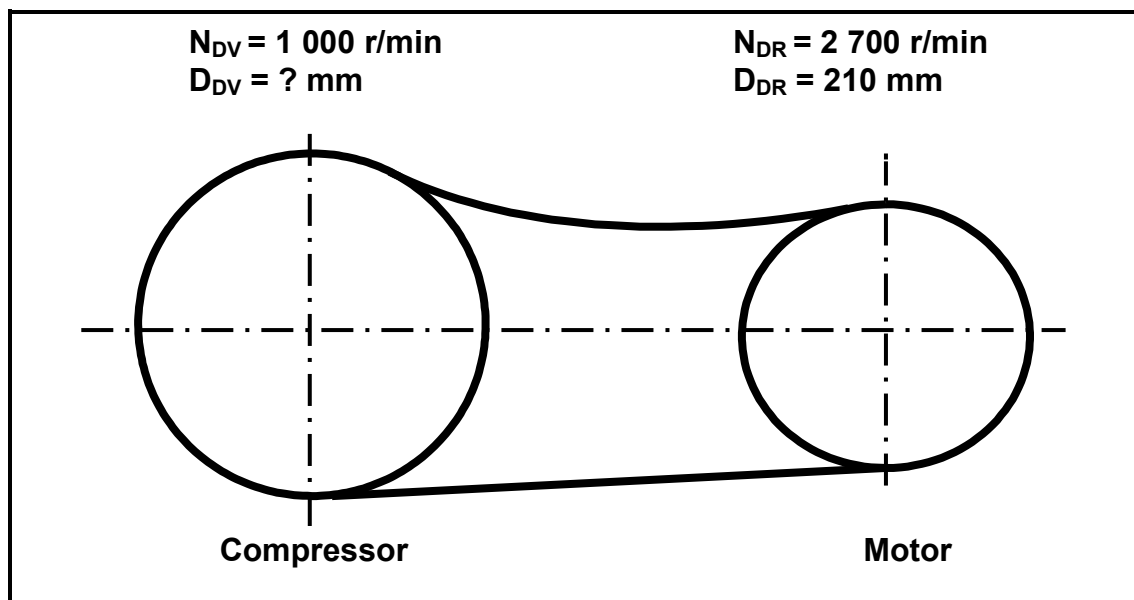

FIGURE 6.2

Determine, by means of calculations, the following:

- 6.3.1 The diameter of the driven pulley in mm (4)
- 6.3.2 The power transmitted, in kilo magnitude, if the effective force in the belt is 400 N (4)
- 6.4 A single-plate friction clutch has an effective diameter of 0,28 m and is able to transmit 336 Nm of torque. The clutch plate has friction material on both sides with a friction co-efficient of 0,3.

Calculate and state the correct units for the following:

- 6.4.1 The total applied force needed on the pressure plate (5)
- 6.4.2 The power transmitted at 2 800 r/min (4)

[50]

TOTAL: 200

FORMULA SHEET FOR MECHANICAL TECHNOLOGY – GRADE 12**1. BELT DRIVES**

$$1.1 \quad \text{Belt speed} = \frac{\pi DN}{60}$$

$$1.2 \quad \text{Belt speed} = \frac{\pi (D + t) \times N}{60} \quad (t = \text{belt thickness})$$

$$1.3 \quad \text{Belt mass} = \text{area} \times \text{length} \times \text{density} \quad (A = \text{thickness} \times \text{width})$$

$$1.4 \quad \text{Speed ratio} = \frac{\text{diameter of driven pulley}}{\text{diameter of driver pulley}}$$

$$1.5 \quad N_1 D_1 = N_2 D_2$$

$$1.6 \quad \text{Open - belt length} = \frac{\pi(D + d)}{2} + \frac{(D - d)^2}{4c} + 2c$$

$$1.7 \quad \text{Crossed-belt length} = \frac{\pi(D + d)}{2} + \frac{(D + d)^2}{4c} + 2c$$

$$1.8 \quad \text{Power (P)} = \frac{2\pi NT}{60}$$

$$1.9 \quad \text{Ratio of tight side to slack side} = \frac{T_1}{T_2}$$

$$1.10 \quad \text{Power (P)} = \frac{(T_1 - T_2)\pi DN}{60} \quad \text{where } T_1 = \text{force in the tight side}$$

$T_2 = \text{force on slack side}$

$T_1 - T_2 = \text{effective force } (T_e)$

$$1.11 \quad \text{Width} = \frac{T_1}{\text{permissible tensile force}}$$

2. FRICTION CLUTCHES

$$2.1 \quad \text{Torque (} T \text{)} = \mu W n R$$

where μ = coefficient of friction

W = total force

n = number of friction surfaces

R = effective radius

$$2.2 \quad \text{Power (} P \text{)} = \frac{2 \pi N T}{60}$$

3. STRESS AND STRAIN

$$3.1 \quad \text{Stress} = \frac{\text{force}}{\text{area}} \quad \text{or} \quad \left(\sigma = \frac{F}{A} \right)$$

$$3.2 \quad \text{Strain (} \varepsilon \text{)} = \frac{\text{change in length (} \Delta L \text{)}}{\text{original length (} L \text{)}}$$

$$3.3 \quad \text{Young's modulus (} E \text{)} = \frac{\text{stress}}{\text{strain}} \quad \text{or} \quad \left(\frac{\sigma}{\varepsilon} \right)$$

$$3.4 \quad A_{\text{shaft}} = \frac{\pi d^2}{4}$$

$$3.5 \quad A_{\text{pipe}} = \frac{\pi(D^2 - d^2)}{4}$$

4. HYDRAULICS

$$4.1 \quad \text{Pressure (} P \text{)} = \frac{\text{Force (} F \text{)}}{\text{Area (} A \text{)}}$$

$$4.2 \quad \frac{F_1}{A_1} = \frac{F_2}{A_2}$$

$$4.3 \quad \text{Work done} = \text{force} \times \text{distance}$$

$$4.4 \quad \text{Volume} = \text{cross-sectional area} \times \text{stroke length (} l \text{ or } s \text{)}$$

5. WHEEL AND AXLE

$$5.1 \quad \text{Velocity ratio (VR)} = \frac{\text{effort distance}}{\text{load distance}} = \frac{2D}{d_2 - d_1}$$

$$5.2 \quad \text{Mechanical advantage (MA)} = \frac{\text{Load (W)}}{\text{Effort (F)}}$$

$$5.3 \quad \text{Mechanical efficiency (}\eta_{\text{mech}}\text{)} = \frac{MA}{VR} \times 100\%$$

6. LEVERS

$$6.1 \quad \text{Mechanical advantage (MA)} = \frac{\text{load (W)}}{\text{effort (F)}}$$

$$6.2 \quad \text{Input movement (IM)} = \text{effort} \times \text{distance moved by effort}$$

$$6.3 \quad \text{Output movement (OM)} = \text{load} \times \text{distance moved by load}$$

$$6.4 \quad \text{Velocity ratio (VR)} = \frac{\text{input movement}}{\text{output movement}}$$

7. SCREW THREADS

$$7.1 \quad \text{Pitch diameter} = \text{outside diameter} - \frac{1}{2} \text{ pitch}$$

$$7.2 \quad \text{Pitch circumference} = \pi \times \text{pitch diameter}$$

$$7.3 \quad \text{Lead} = \text{pitch} \times \text{number of starts}$$

$$7.4 \quad \text{Helix angle: } \tan \theta = \frac{\text{lead}}{\text{pitch circumference}}$$

$$7.5 \quad \text{Leading tool angle} = 90^\circ - (\text{helix angle} + \text{clearance angle})$$

$$7.6 \quad \text{Following/Trailing angle} = 90^\circ + (\text{helix angle} - \text{clearance angle})$$

$$7.7 \quad \text{Number of turns} = \frac{\text{height}}{\text{lead}}$$

8. GEAR DRIVES

$$8.1 \quad \text{Power (} P \text{)} = \frac{2 \pi NT}{60}$$

$$8.2 \quad \text{Gear ratio} = \frac{\text{product of the number of teeth on driven gears}}{\text{product of the number of teeth on driving gears}}$$

$$8.3 \quad \frac{N_{\text{input}}}{N_{\text{output}}} = \frac{\text{product of the number of teeth on driven gears}}{\text{product of the number of teeth on driving gears}}$$

$$8.4 \quad \text{Torque} = \text{force} \times \text{radius}$$

$$8.5 \quad \text{Torque transmitted} = \text{gear ratio} \times \text{input torque}$$

$$8.6 \quad \text{Module (} m \text{)} = \frac{\text{Pitch-circle diameter (PCD)}}{\text{Number of teeth (} T \text{)}}$$

$$8.7 \quad N_1 T_1 = N_2 T_2$$

$$8.8 \quad \text{Pitch-circle diameter (PCD)} = \frac{\text{circular pitch (CP)} \times \text{number of teeth (} T \text{)}}{\pi}$$

$$8.9 \quad \text{Outside diameter (OD)} = \text{PCD} + 2 \text{ module}$$

$$8.10 \quad \text{Addendum (} a \text{)} = \text{module (} m \text{)}$$

$$8.11 \quad \text{Dedendum (} b \text{)} = 1,157 m \quad \text{or} \quad \text{Dedendum (} b \text{)} = 1,25 m$$

$$8.12 \quad \text{Cutting depth (} h \text{)} = 2,157 m \quad \text{or} \quad \text{Cutting depth (} h \text{)} = 2,25 m$$

$$8.13 \quad \text{Clearance (} c \text{)} = 0,157 m \quad \text{or} \quad \text{Clearance (} c \text{)} = 0,25 m$$

$$8.14 \quad \text{Circular pitch (CP)} = m \times \pi$$

9. CINCINNATI DIVIDING HEAD TABLE FOR THE MILLING MACHINE

<i>Hole circles</i>											
<i>Side 1</i>	24	25	28	30	34	37	38	39	41	42	43
<i>Side 2</i>	46	47	49	51	53	54	57	58	59	62	66

<i>Standard change gears</i>										
24 x 2	28	32	40	44	48	56	64	72	86	100

9.1 Simple indexing = $\frac{40}{n}$ (where n = number of divisions)

9.2 Change gears:

$$\frac{Dr}{Dv} = (A - n) \times \frac{40}{A} \quad \text{or} \quad \frac{Dr}{Dv} = \frac{(A - n)}{A} \times \frac{40}{1} \quad \text{or} \quad \frac{Dr}{Dv} = (N - n) \times \frac{40}{N}$$

10. CALCULATIONS OF FEED

10.1 Feed (f) = $f_1 \times T \times N$

Where: f = feed in millimetres per minute

f_1 = feed per tooth in millimetres

T = number of teeth on cutter

N = number of revolutions of cutter per minute

10.2 Cutting speed (V) = $\pi \times D \times N$

Where: D = diameter of the cutter in metres